

This Guide to Quantities is only applicable to Data Sheet E147.2.

Specification for Individual Panels

	Weatherfold 4s 50	Weatherfold 4s 100
Track System	E147	E147
Refer to Data Sheet		
Max Panel Height	3000mm	3300mm
Max Panel Weight	50kg	100kg
Max Panel Width	1000mm	1000mm
Min Panel Thickness	35mm	35mm
Max Number of Panels	8 each direction	8 each direction

2 Panel Unit

	Quantities	Product Codes	
Track	1	180A-A20	350-A20
Pivot Set	1	BWS1-100M	BWS1-100M
Hinge Handle Set	1	BW3-100M	BW3-100M
End Hanger Set	1	BWS2-50SM	BWS2-100SM
Flush Bolt Top	1	456	456
Flush Bolt Bottom	1	456E	456E
Channel	1	94PPA-A20	94PPA-A20

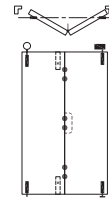

3 Panel Unit

	Quantities	Product Codes	
Track	1	180A-A30	350-A30
Pivot Set	1	BWS1-100M	BWS1-100M
Offset Hinge Handle Set	1	BW7-100M	BW7-100M
Intermediate Hanger Set	1	BWS4-50SM	BWS4-100SM
Flush Bolt Top	1	456	456
Flush Bolt Bottom	1	456E	456E
Channel	1	94PPA-A30	94PPA-A30

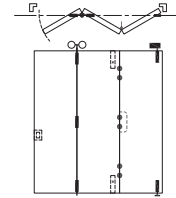

4 Panel Unit

	Quantities	Product Codes	
Track	1	180A-A40	350-A40
Pivot Set	1	BWS1-100M	BWS1-100M
Offset Hinge Handle Set	2	BW7-100M	BW7-100M
Intermediate Hanger Set	1	BWS4-50SM	BWS4-100SM
End Hanger Set	1	BWS2-50SM	BWS2-(75/100)SM
Flush Bolt Top	2	456	456
Flush Bolt Bottom	2	456E	456E
Channel	1	94PPA-A40	94PPA-A40

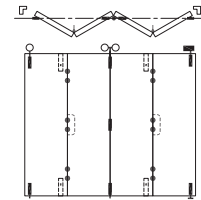

4 Panel Unit 'Floating'

	Quantities	Product Codes	
Track	1	180A-A40	350-A40
Offset Hinge Handle Set	2	BW7-100M	BW7-100M
Intermediate Hanger Set	1	BWS4-50SM	BWS4-100SM
End Hanger Set	2	BWS2-50SM	BWS2-100SM
Flush Bolt Top	2	456	456
Flush Bolt Bottom	2	456E	456E
Channel	1	94PPA-A40	94PPA-A40

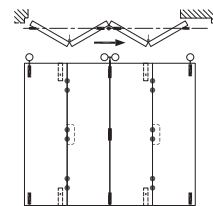

2+2 Panel Unit

	Quantities	Product Codes	
Track	1	180A-A40	350-A40
Pivot Set	2	BWS1-100M	BWS1-100M
Hinge Handle Set	2	BW3-100M	BW3-100M
End Hanger Set	2	BWS2-50SM	BWS2-100SM
Flush Bolt Top	2	456	456
Flush Bolt Bottom	2	456E	456E
Channel	1	94PPA-A40	94PPA-A40

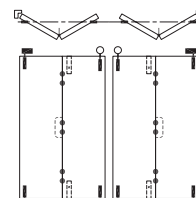

5 Panel Unit

	Quantities	Weatherfold 4s 50 Product Codes	Weatherfold 4s 100 Product Codes
Track	1	180A-A60	350-A60
Pivot Set	1	BWS1-100M	BWS1-100SM
Intermediate Hanger Set	2	BWS4-50SM	BWS4-100SM
Offset Hinge Handle Set	1	BW7-100M	BW7-100M
Hinge Handle Set	1	BW3-100M	BW3-100M
Flush Bolt Top	2	456	456
Flush Bolt Bottom	2	456E	456E
Channel	1	94PPA-A60	94PPA-A60

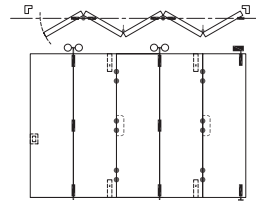

6 Panel Unit

	Quantities	Weatherfold 4s 50 Product Codes	Weatherfold 4s 100 Product Codes
Track	1	180A-A60	350-A60
Pivot Set	1	BWS1-100M	BWS1-100SM
Intermediate Hanger Set	2	BWS4-50SM	BWS4-100SM
Hinge Handle Set	3	BW3-100M	BW3-100M
End Hanger Set	1	BWS2-50SM	BWS2-100SM
Flush Bolt Top	3	456	456
Flush Bolt Bottom	3	456E	456E
Channel	1	94PPA-A60	94PPA-A60

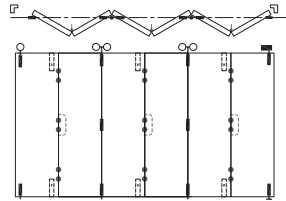

6 Panel Unit 'Floating'

	Quantities	Weatherfold 4s 50 Product Codes	Weatherfold 4s 100 Product Codes
Track	1	180A-A60	350-A60
Intermediate Hanger Set	2	BWS4-50SM	BWS4-100SM
Offset Hinge Handle Set	2	BW7-100M	BW7-100M
Hinge Handle Set	1	BW3-100M	BW3-100M
End Hanger Set	2	BWS2-50SM	BWS2-100SM
Flush Bolt Top	3	456	456
Flush Bolt Bottom	3	456E	456E
Channel	1	94PPA-A60	94PPA-A60

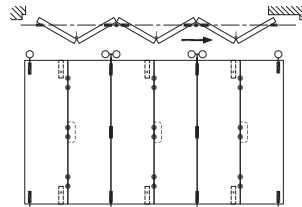

2 Additional Panels to Increase 5 or 6 Panels to 7 or 8 Panels

	Quantities	Weatherfold 4s 50 Product Codes	Weatherfold 4s 100 Product Codes
Track	1	180A-A60	350-A60
Intermediate Hanger Set	1	BWS4-50SM	BWS4-100SM
Hinge Handle Set	1	BW3-100M	BW3-100M
Flush Bolt Top	1	456	456
Flush Bolt Bottom	1	456E	456E
Channel	1	94PPA-A20	94PPA-A20

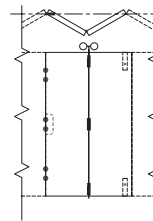

Application

For residential and commercial folding systems where weatherproofing of the opening is required.

This section covers Weatherfold 4s 50 & 100 Mortice Square Corner Hinge hardware for timber panels. The high-strength hinges are manufactured from 3mm thick stainless steel with square corners.

For extra corrosion resistance, Weatherfold 4s is supplied with precision stainless steel bearings. Hangers are cast 316 marine stainless steel.

Panel Specification

Track System:	Weatherfold 4s 50	Weatherfold 4s 100
Max Panel Height	3000mm	3300mm
Max Panel Weight	50kg	100kg
Max Panel Width	1000mm	1000mm
Panel Thickness	35mm	35mm
Max Number of Panels	8 each direction	8 each direction

Hardware Specification

Track:	180A	350
Material	Clear Anodised	
Standard Lengths	2000mm, 3000mm, 4000mm and 6000mm	

Hanger Sets:		
Intermediate Hanger Set:	BWS4-50SM	BWS4-100SM
End Hanger Set:	BWS2-50SM	BWS2-100SM

Pivot Sets:	BWS1-100M	BWS1-100M

Jamb Pivot:	BW189M	BW189M

Hinge Sets:		
Hinge Handle Set	BW3-100M	BW3-100M
Offset Hinge Handle Set	BW7-100M	BW7-100M
Hinge Set	BW5-100M	BW5-100M
Offset Hinge Set	BW6-100M	BW6-100M

Channels:		
Polypropylene	94P	94P
Polyprop Plus Support	94PPA	94PPA
Aluminium	94A	94A
Standard lengths	2000mm, 3000mm, 4000mm and 6000mm	

Accessories:		
Flush Pull	401	401
Flush Bolt - 190mm	456	456
Flush Bolt - 450mm	456L	456L
Security Aligner	199SS	199SS
Frame Seal - White	AQ21W	AQ21W
Frame Seal - Brown	AQ21B	AQ21B
Door Seal - White	AQ63W	AQ63W
Door Seal - Brown	AQ63B	AQ63B
Track Seal	PS13B	PS13B

Finish options
 Hardware: (SS) Satin Stainless, (PS) Polished Stainless, (PB) PVD Brass.
 Flush bolts: (SN) Safin Nickel, (PVDB) PVD Brass.

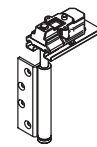
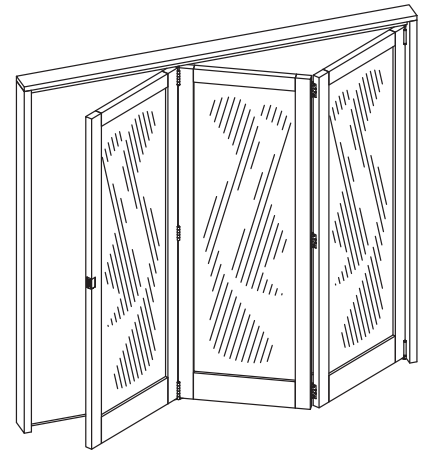

No. BWS1-100H PIVOT SET

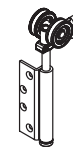

No. BWS2-50M END HANGER & GUIDE SET

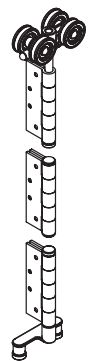

No. BWS4-50M INTERMEDIATE HANGER & GUIDE SET



No. BW3-100M HINGE HANDLE SET



No. BW5-100M HINGE SET



No. BW6-100M OFFSET HINGE SET



No. BW7-100M OFFSET HINGE HANDLE SET

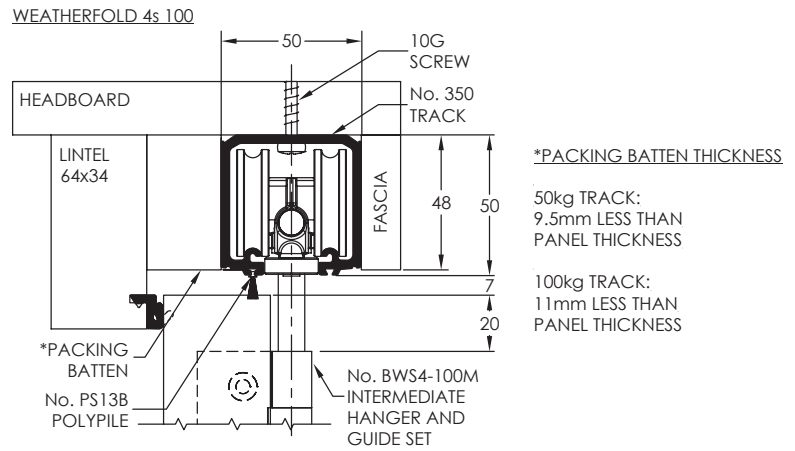
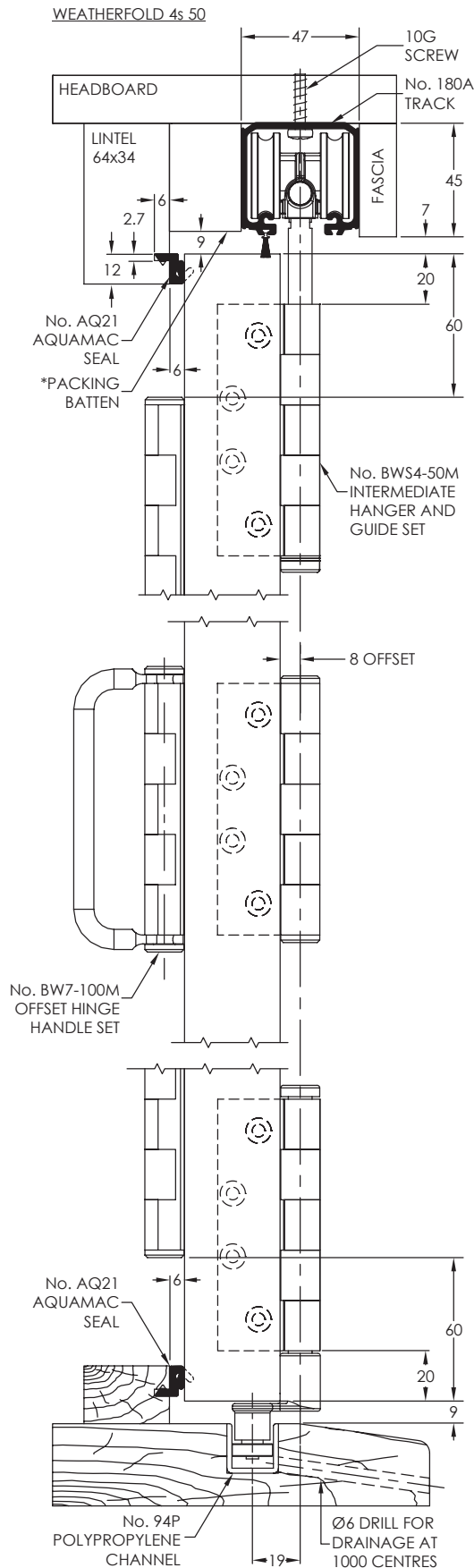

4+0 PANEL OUTWARD OPENING SYSTEM - CLOSED
(SHOWN WITHOUT TRACK OR HEAD SECTION)

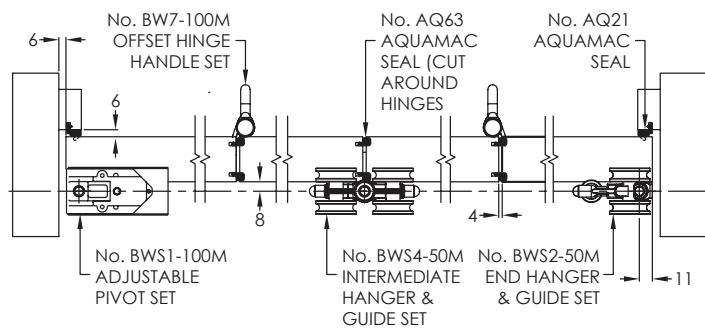

4+0 PANEL OUTWARD OPENING SYSTEM - OPEN
(SHOWN WITHOUT HEAD SECTION)

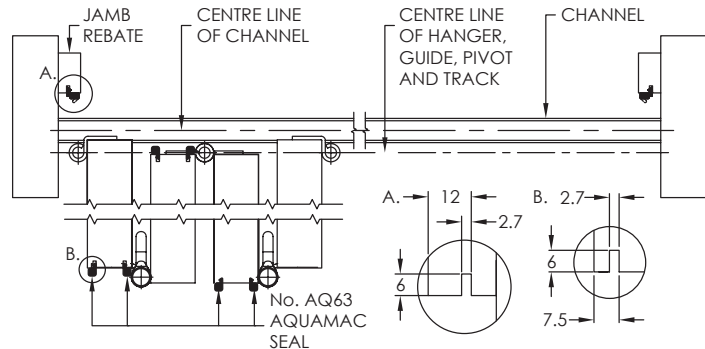

4+0 PANEL OUTWARD OPENING SYSTEM - CLOSED
(TYPICAL OUTSIDE ELEVATION)

